



# VOIR LA VILLE



PHOTOGRAPHIE \_ JULIE GUICHES

GRAPHISME \_ DEBORAH ROBIANO









































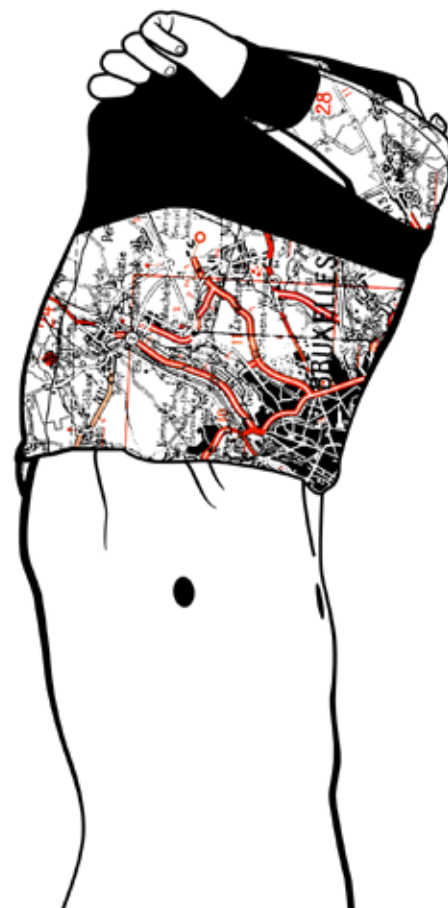





# INSTALLATIONS







## Disconnect Unit

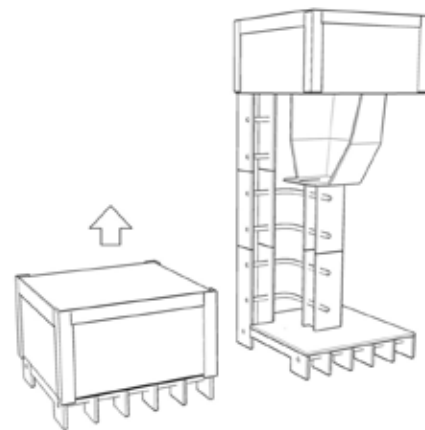

Conçue comme une cabane en kit, DU est un refuge minimum permettant seulement à la tête (et donc l'imagination) d'une seule personne d'échapper à la réalité environnante.

Le positionnement de 3 miroirs face à face nous permet d'obtenir un reflet à l'infini à l'intérieur de la boîte. Collés sur les miroirs des éléments photographiques viennent compléter le piège optique mis en place.

*Design - Damien Chiuialle*

*Montage optique - Julie Guiches*

*Co-Production - Recyclart - Petit Bain*



## Zero Gravity



Roue de hamster géante + habillage photographique ( intérieur, extérieur).

ZG. 1 RUN! Dissimulateur pour jogger  
*SmartCity, Emergences, CIUP, Paris, 2008*

Anamorphose en façade pour courir à l'abris des caméras de vidéo-surveillance.

*Design - Damien Chiuialle  
Montage optique - Julie Guiches*

*Co-Production - Recyclart - Petit Bain*



## Anamorphose 3D

Installation photographique fonctionnant comme un jeu d'optique, une image décomposée, qui se recompose d'un unique point de vue.

*Design - Jean-François Rouvéri  
Photographie - Julie Guichet*

*Production - ArtSenat 2005  
L'art dans la ville, Jardin du Luxembourg, Paris.*





## Tapis de foule

Parc de Belleville,  
*Paris, 2006*





## Panoramiques

*Variaciones Cartograficas*  
*Uitoria-Gazeist, Espagne, 2007*

*Festival d'Architecture Eme3*  
*Poble Nou, Barcelone, 2005*

*Festival Sous la plage*  
*Parc André Citroën, Paris, 2006*







## Hotel Metavilla

Intervention au sein du collectif EXYZT invité par l'architecte Patrick Bouchain.

Création d'un hotel capsules de 12 chambres et un dortoir collectif à l'intérieur du Pavillon Français .

Habillage photographique de 6 chambres avec des résilles.

*H° Biennale d'Architecture,  
Venise, Italie, 2006*







**PHOTOGRAPHY © JULIE GUICHES**

[JULIE@STUDIO-PUBLIC.ORG](mailto:JULIE@STUDIO-PUBLIC.ORG)

[WWW.STUDIO-PUBLIC.ORG](http://WWW.STUDIO-PUBLIC.ORG)

[HTTP://PICTURETANK.COM/JULIEGUICHES](http://PICTURETANK.COM/JULIEGUICHES)

**GRAPHIC DESIGN © DEBORAH ROBBIANO**

[DEBORAH.ROBBIANO@GMAIL.COM](mailto:DEBORAH.ROBBIANO@GMAIL.COM)